

# AERZEN SCREW COMPRESSORS

New Aerzen Screw Compressor Units  
Delta Screw Generation 5  
Intake volume flows from 270 m<sup>3</sup>/h up to 2.600 m<sup>3</sup>/h



**AERZENER MASCHINENFABRIK  
GMBH**

V1-019 | 00 | EN

2000 4.2008

**It's new:**

# Delta Screw 5 Generation

*stands for the new series  
of compressor units made by  
Aerzener Maschinenfabrik*

## Customers Benefit from Technical Progress

Aerzener Maschinenfabrik started manufacturing oil-free screw compressors in 1943 and is proud to be one of the oldest and largest manufacturers worldwide, with a market leading position in Europe. Technical competence, experienced staff and constant dialogue with our customers maintain the basis for the successful developments from Aerzen, reflecting in quality and reliability of our products.



## The new generation

The screw compressor unit Delta Screw Generation 5 is the synthesis of the successful characteristics developed in previous generations combined with new technical innovations that already meet the market requirements of the future.

## Why Generation 5?

Aerzener Maschinenfabrik was the first compressor manufacturer to design a compact unit and has developed this machine type continuously ever since. Delta Screw Generation 5 is therefore the fifth generation of Aerzen compressor units and represents the successful combination of tradition and innovation. The considerable experience in manufacturing oil-free compressors is the guarantor for high-quality and most reliable compressor units. However compared to other compressor models this new series offers 5 main advantages for the customers. 5 main advantages which led to the name "Generation 5".

### ➤ Energy efficiency and reduction of Life-Cycle-Costs

The Aerzen screw compressors distinguish themselves by two different rotor profiles, which is a criterion which is so far unique on the market for screw compressors.

For low-pressure applications up to 2 bar (g) a specially designed 3 + 4-profile (VML-compressors), for higher pressures up to 3,5 bar (g) a 4 + 6-profile (VM-compressors) is available.

VML



VM

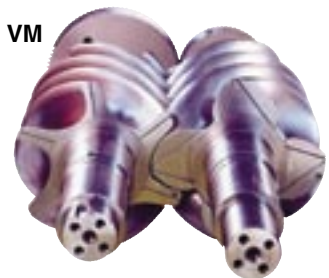

Therefore, depending on the individual case of application and pressure range the most energy efficient compressor type is available. The energy efficiency increases additionally with by two different outlets per rotor profile, arranged according to pressure and volume flow for an optimum of internal compression. The different internal pressure ratios avoid possible over compression, the efficiency of the machines increases e.g. in the low pressure range up to 2 bar an energy efficiency of more than 20% compared with other compressor models may result. The G5 design has incorporated a number of technical revisions to the components of the package. Due to innovations in discharge pressure silencing, pressure losses have been reduced by up to 20%.

## Sound pressure level of a VM 21 R-G5 screw compressor unit

determined acc. to the sound intensity procedure

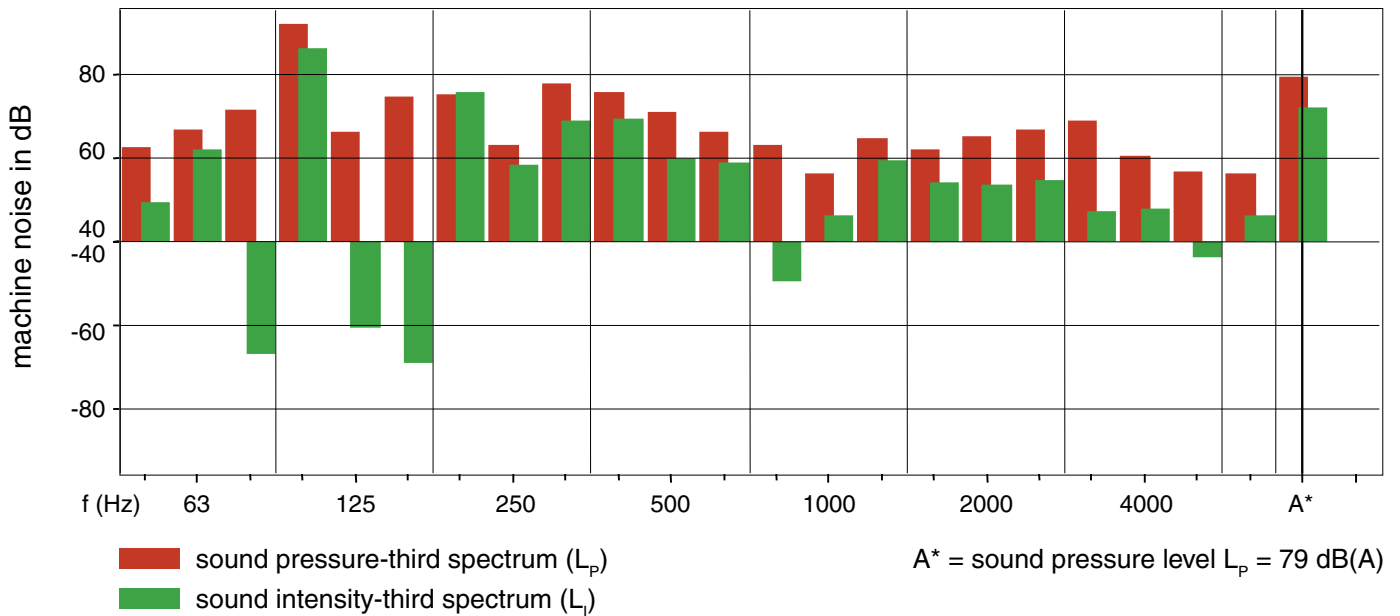

As standard high efficiency EFF1 motors are used. This provides energy savings of up to 3 %.

As two thirds of the Life-Cycle-Costs of compressors are determined by their energy consumption, the investment costs, when deciding for an Aergen compressor unit, allow pay back after a short time. Maintenance costs which account for up to 20 % are another essential factor when considering Life-Cycle-Costs. The design innovations associated with the new Delta Screw Generation 5 have been made with this factor in mind (see page 5).

### ➤ Lower Sound Levels

Compared with the previous generation the sound levels of the new Delta Screw Generation 5 could be reduced by an average of about 6 dB(A), in some cases even more. No absorption material is used – making the units suitable for foodgrade applications.

Due to these considerable sound reductions, expensive special measures (such as special acoustic hoods) are no longer required.



## ➤ ATEX-certification

The translation of the European machine directive 94/9/EG for explosion-hazardous areas is becoming more and more important in all branches and ranges of application. The compressor units made by Aerzener are especially designed for the requirements in categories 2 and 3 for dust- as well as gas zones and certified accordingly. In addition the new units Delta Screw Generation 5 distinguish themselves by a special solution for explosion protection in pneumatic conveying of bulk material. If combustible bulk material is conveyed pneumatically, in the unit in case of certain dust-air concentrations inflammable mixtures may develop. On the basis of the EU-directive 1999/92/EG (ATEX 137) therefore an additional protection e.g. by means of an external spark arrester in connection with compressors is to be provided. The Delta Screw Generation 5 design has taken this point into consideration.

The newly designed discharge silencer of the Aerzen compressor units is free from absorption material, the sound is dampened only by means of air-redirections. After tests this silencer can now be certified in addition as spark arrester. External spark arresters are no longer necessary! Besides utmost safety, costs are saved with pressure- and energy losses reduced considerably.

## Schematic description in case of pressure conveyance

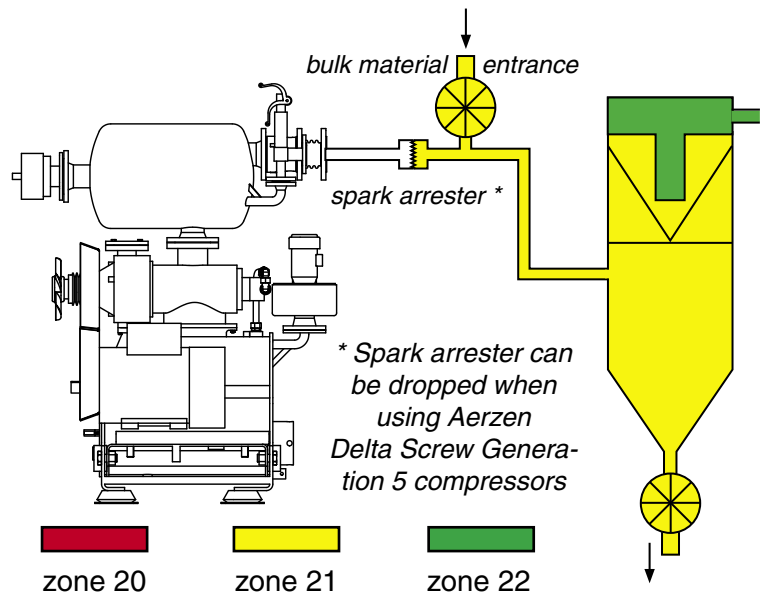

## ➤ Space saving design

The new compressor units Delta Screw Generation 5 distinguish themselves by their very compact construction. Additionally the installation option „Side-by-Side“ is available, i.e. the units can be installed directly one beside the other, without leading to disadvantages for services and maintenances. The reduction of space can therefore lead to savings with smaller machine rooms.

**5 sizes in 2 nominal widths:**  
Low space requirement due to compact construction and installation option "Side-by-Side".



### ➤ Easy operation and maintenance

During development of the new units, special consideration was given to the ease of handling of the machines and reduction of the maintenance expenditure. Easy handling starts with easy installation:

The new design units can be easily transported at site, by means of a four wheel pallet truck and/or fork lift trucks. An integrated service package simplifies the commissioning as well as further service tasks.

The units are operated from the front. All components requiring maintenance are easily accessible. One of the most important advantages is the new oil system. The oil level can be viewed and checked from the outside of the unit while it is still in operation without any problems. Compressor shutdowns, process and production interruptions belong to the past.



The patented drive concept with belt drive also leads to a reduction in maintenance expenditure and thus reduction of the Life-Cycle-Costs. Concerning the Aerzen concept the drive motor is installed on a hinged motor mounting plate and with its own weight always arranges for optimal belt tension.

Retensioning - even after a longer period of operation - is no longer necessary. In addition this new concept makes supplementary adjusting of the performance data possible (pressure/volume flow) by means of easy and favourable-priced changing of the pulleys.



Further advantages of the new series Delta Screw Generation 5:

- No use of absorption material (foodstuff-compatibility!)
- Mechanical fan
- Class 0-certification (oil-free)
- Approval acc. to PED-, ASME-, RTN-directive as well as China Licence



**Easy operation and maintenance:**  
*The maintenance work “oil” and “filter” is carried out from the front.*

**The oil level can be checked from the outside when the compressor is running.**



## Scope of supply and performances:

- Aerzen screw compressor stage with reinforced bearings of driving shaft (secondary rotor) suitable for belt drive, forced-feed oil lubrication incl. oil pump, oil filter, oil pressure regulating valve, turbo filter for oil chamber release
- Base support with hinged motor mounting plate
- Intake filter (single-stage) and intake silencer integrated in base support
- Belt drive with belt guard (optional)
- Discharge silencer without absorption material
- Safety relief valve (type-tested)
- Non-return valve
- Expansion joint for connection to the pressure pipe
- Flex. machinery mountings with anchor bolts
- Electronic control system AS 200 for protection of the machine with indication and monitoring for intake-, discharge- and oil pressure, discharge- and oil temperature, single fault indication and operating hour meter

## Accessories: Options

- 3 phase motor including mounting at Aerzen
- Acoustic hood for the complete compressor unit for indoor- and outdoor installation
- Start-up unloading valve for VML-compressors (self-controlled)
- Constant-speed unloading device for VM-compressors including suction throttle, unloading valve and pressure switch PSLH (self-controlled)
- Power cabinet for starting the machine ( e.g. direct starting, star-delta)
- Frequency converter, designed as separate cabinet (installation and external wiring at site)
- Overflow regulating valve (self-controlled) for keeping the discharge pressure constant, or vacuum, provided in unfixed condition for installation into the pipework at site
- Separate aftercooler, provided in unfixed condition for installation into the pressure pipe at site, designed as air-/aircooler or air/water- cooler. In case of risk of forming of condensate on request also with cyclone separator and automatic drain.



### Modifications: Options

- Nitrogen-design incl. suction silencer, starting strainer, expansion joint suction-sided, suction-pressure gauge
- ATEX-design (EEx) of main- and auxiliary drives for various requirements (e.g. EEx e or EEx de)
- Special instrumentation in coordination with customers' specification
- Special painting
- ANSI-flanges for connection to suction- or discharge-sided pipe
- Vacuum-design (also with pre-inlet) incl. suction silencer, expansion joint suction-sided, suction-pressure gauge, suction valve, vacuum filter as option
- ATEX 100A-certification
- ATEX-certification as spark arrester
- Approval acc. to PED-, ASME-, RTN- directive as well as China Licence

### Instrumentation and monitoring

Aerzen Universal control unit AS 200 including instrumentation in analogue technology with pressure transmitter for intake-, discharge- and oil pressure as well as resistance thermometer for discharge- and oil temperature.

The indications are optionally available (multilingual) in the display, control options for various cases of operation, indication of service intervals, limit value detection as fault indication archive, Modbus interface (RS 485) for data transmission (e.g. remote diagnosis, remote control – design not ex-proof).



## Fields of application and use

Aerzen compressor units are designed for conveying air and neutral gases. At present, the series Delta Screw Generation 5 is available as belt-driven design for overpressure-, vacuum – and nitrogen applications with nominal widths DN 125 to DN 200. Using a flexible modular construction makes it possible for all compressors and motor sizes for belt drive to be installed within a range of nominal widths. Thus adjustments to speed and power are easily possible without problems. The new series Generation 5 consists of 7 sizes (sizes VM 37 R and VML 40 R in preparation) for intake volume flows from approx. 270 m<sup>3</sup>/h up to 2.600 m<sup>3</sup>/h and overpressures up to 3,5 bar. In vacuum operation the VML compressors can be used up to 70 % vacuum (0,3 bar abs.), as special design up to 85 % vacuum (0,15 bar abs.). The entire series Delta Screw includes 15 sizes and volume flows up to 15.000 m<sup>3</sup>/h.



Examples for the various fields of application:

- Pneumatic transport with air or N<sub>2</sub>
- Aeration of sewage basins
- Homogenizing of cement
- Vacuum generation in glass industry
- Keeping lakes and harbours free from ice
- Installing oil traps
- Gas-air mixing plants
- Oxidation air for power stations
- Stationary unloading of silo vehicles
- Vacuum generation in paper industry
- Conveying and compressing neutral gases
- Blowing air for manufacturing spunbonded web
- and many more



## Flow scheme VML compressors – filter suction, with start-up unloading device

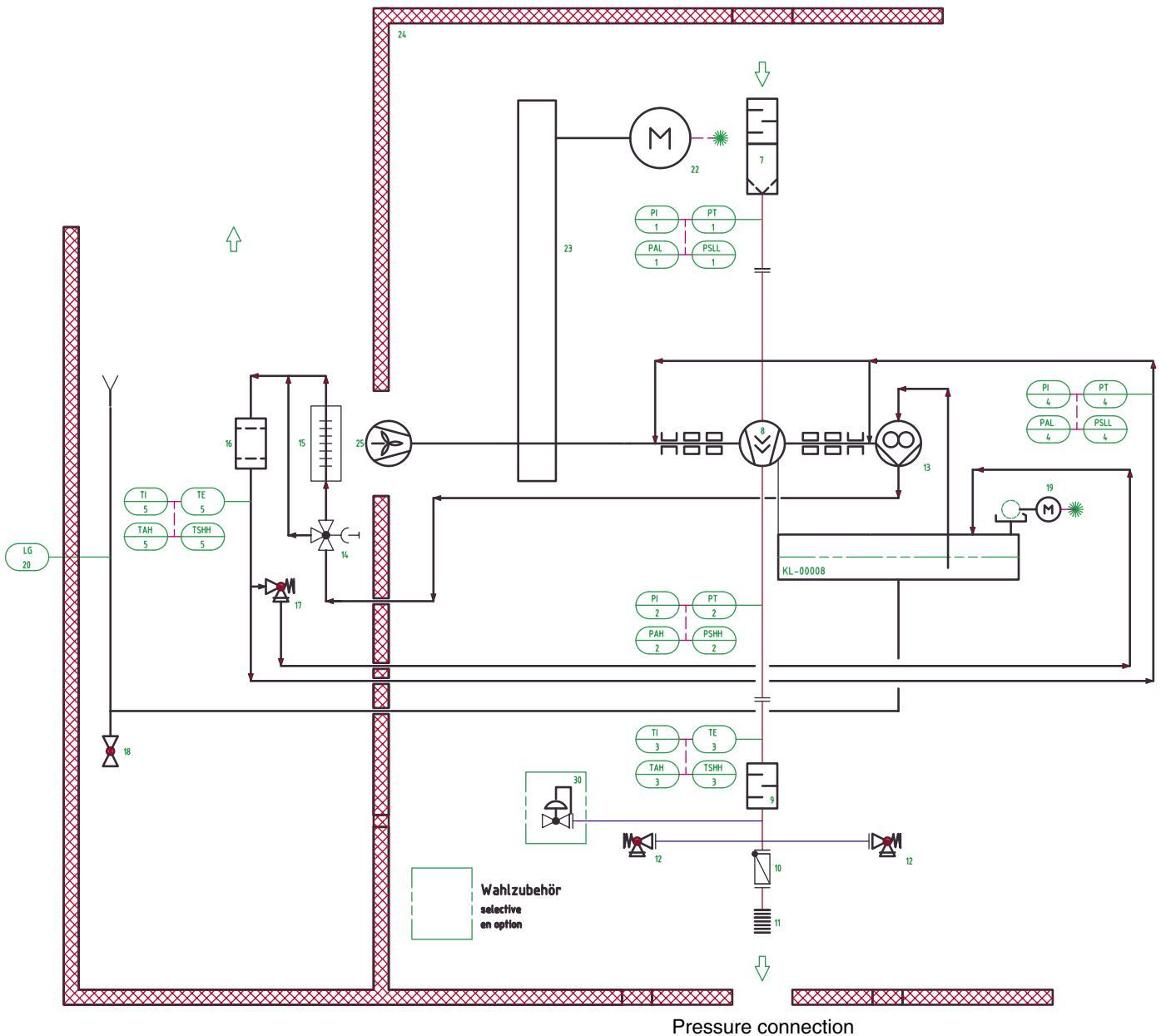

- 1 intake pressure
- 2 discharge pressure
- 3 discharge temperature
- 4 oil pressure
- 5 oil temperature
- 6 system pressure
- 7 intake filter silencer
- 8 compressor stage
- 9 discharge silencer
- 10 non-return flap
- 11 expansion joint

- 12 safety relief valve (2x)
- 13 oil pump
- 14 oil temperature regulator
- 15 oil air cooler
- 16 oil filter
- 17 oil overflow valve
- 18 oil drain valve
- 19 oil demister
- 20 oil sight glass
- 22 electric motor
- 23 belt drive

- 24 acoustic hood
- 25 fan

The following item does not belong to our scope of supply and is available against extra price:

- 30 start-up unloading device

## Flow scheme VM compressors – filter suction, with constant speed unloading device

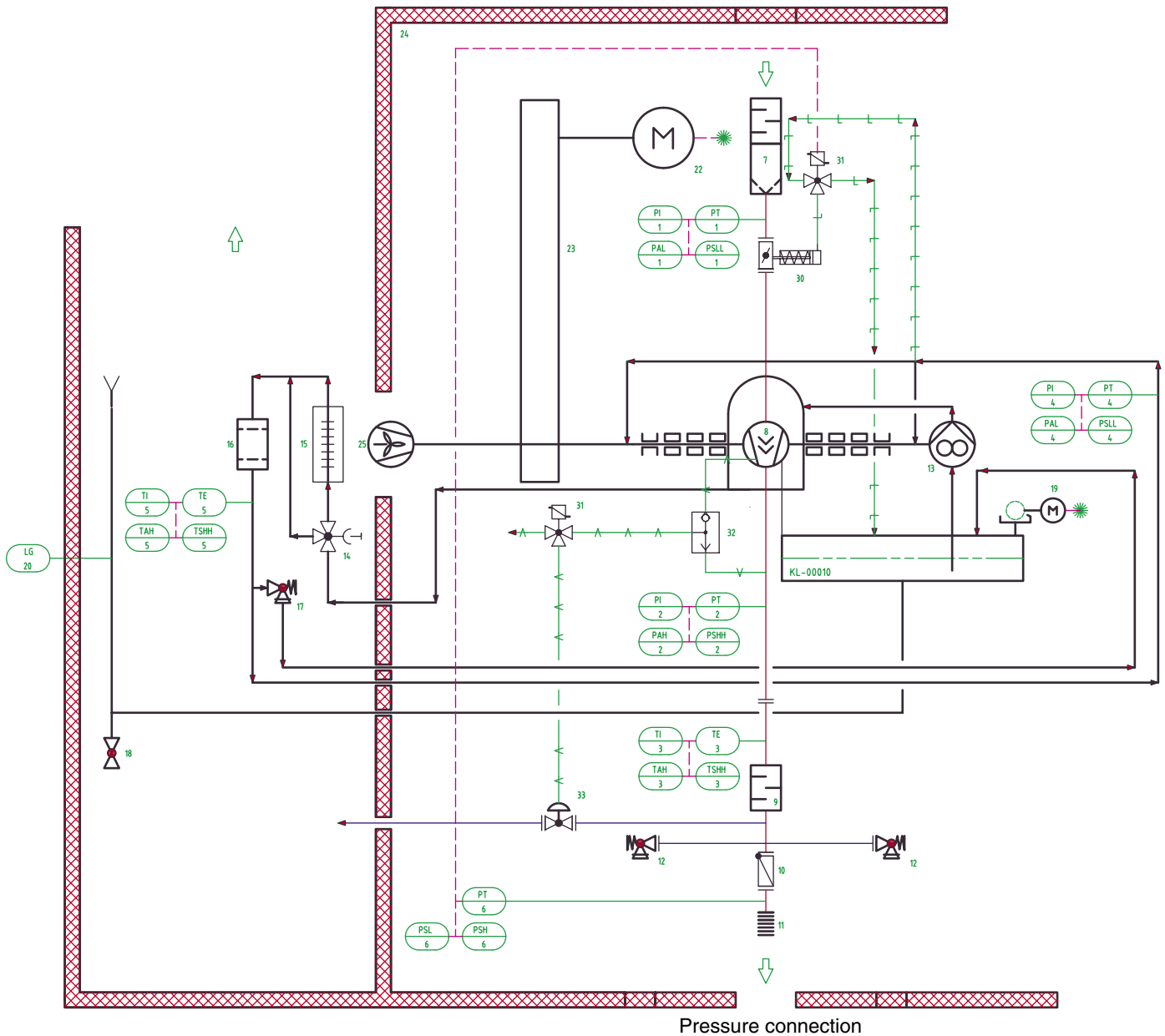

- 1 intake pressure
- 2 discharge pressure
- 3 discharge temperature
- 4 oil pressure
- 5 oil temperature
- 6 system pressure
- 7 intake filter silencer
- 8 compressor stage
- 9 discharge silencer
- 10 non-return flap
- 11 expansion joint

- 12 safety relief valve (2x)
- 13 oil pump
- 14 oil temperature regulator
- 15 oil air cooler
- 16 oil filter
- 17 oil overflow valve
- 18 oil drain valve
- 19 oil demister
- 20 oil sight glass
- 22 electric motor
- 23 belt drive

- 24 acoustic hood
- 25 fan

The following items do not belong to our scope of supply and are available against extra price:

- 30 throttle-flap control
- 31 3-way-solenoid valve (2 x)
- 32 pressure selection relay
- 33 relief valve

## Dimensions – DELTA SCREW – VML 18 R-G5 to VM 37 R-G5

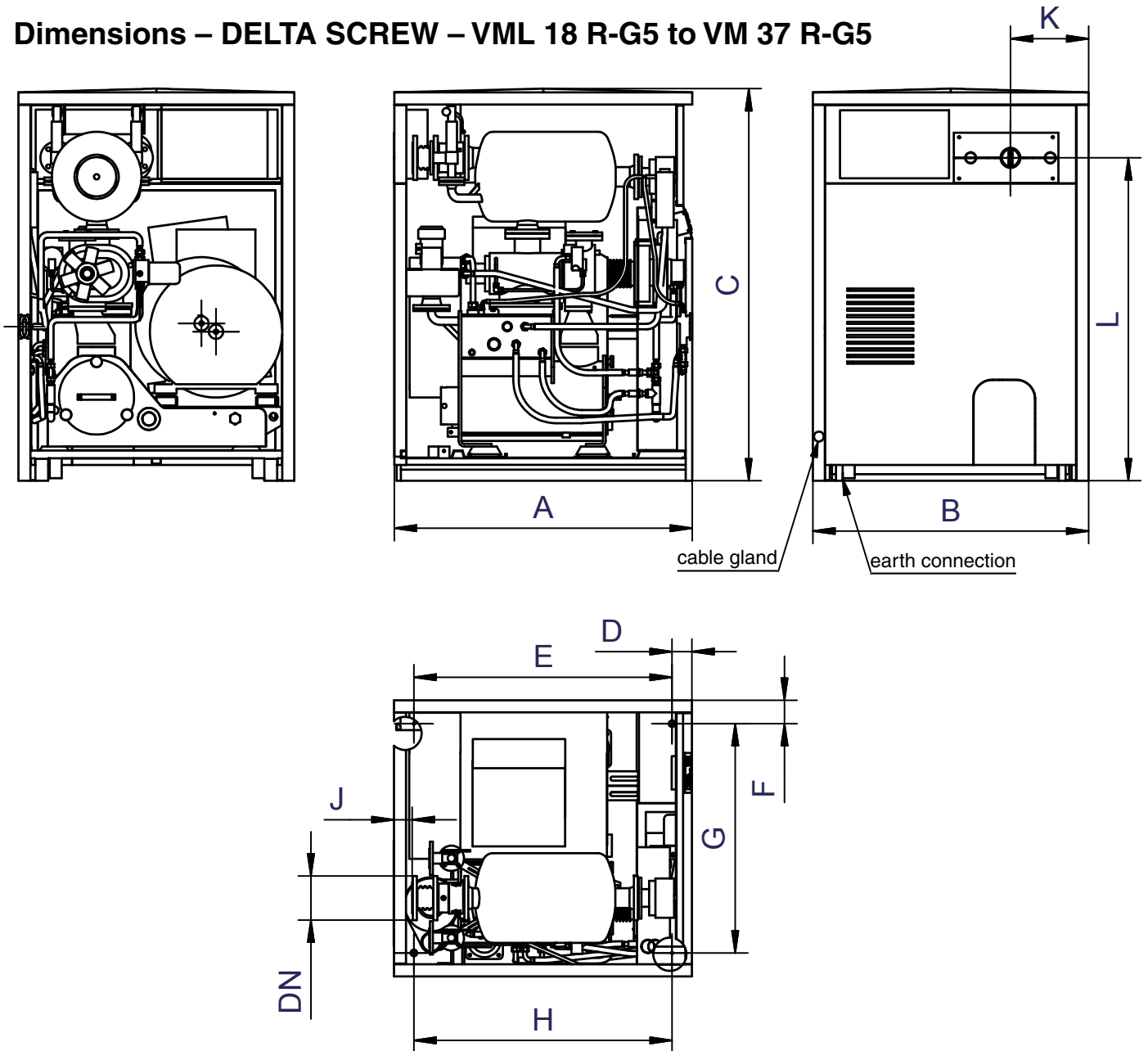

size	A [mm]	B [mm]	C [mm]	H [mm]	K [mm]	L [mm]	DN DS	PN	oil filling ltr.	weight approx. kgs without motor
VML 18 R-G5	1350	1250	1776	1170	355	1470	80	16	12	960
VML 25 R-G5	1800	1500	1978	1475	432	1646	125	16	25	1500
VML 40 R-G5 *							150	16	36	
VM 8 R-G5	1350	1250	1776	1170	395	1462	65	16	22	900
VM 15 R-G5	1350	1250	1776	1170	395	1462	65	16	30	960
VM 21 R-G5	1800	1500	1978	1475	631	1714	80	16	30	1520
VM 37 R-G5 *							150	16	54	

\* in preparation

dimensions (in mm) not binding / weights without motor and belt drive!

## Performance data

### Overpressure, max. data

compressor size ***	pressure bar	volume flow m <sup>3</sup> /h	motor rating kW	sound pressure level (+/- 2 dB(A))
VM 8 R-G5	3,5	497	55	79
VM 15 R-G5	3,5	966	90	79
VML 18 R-G5	2,0	1252	75	79
VM 21 R-G5	3,5	1461	132	80
VML 25 R-G5	2,0	1754	110	80
VM 37 R-G5 **	3,5	2323	200	80
VML 40 R-G5 **	2,0	2592	132	80

\*\* in preparation

\*\*\* different sizes and designs in preparation, available as existing Delta Screw series

### Negative pressure, max. data

compressor size***	differential pressure bar	volume flow m <sup>3</sup> /h	motor rating kW	sound pressure level (+/- 2 dB(A))
VM 8 R-G5	0,8	450	15	76
VM 15 R-G5	0,8	900	22	76
VML 18 R-G5	0,7	1200	30	76
VML 18 R-G5 *	0,85	840	37	75
VML 25 R-G5	0,7	1700	37	79
VML 25 R-G5 *	0,85	1260	45	78
VML 40 R-G5 **	0,7	2300	45	78

\* pre-inlet machine

\*\* in preparation

\*\*\* different sizes and designs in preparation, available as existing Delta Screw series



## Aerzen Machines Ltd.

Aerzen House, Langston Road, Loughton, Essex, IG10 3SQ / United Kingdom  
Phone + 44 20 85 02 81 00 · Fax + 44 20 85 02 81 02 · aerzen@aerzengb.com